

# ROTRA

Antriebsentwicklung GmbH

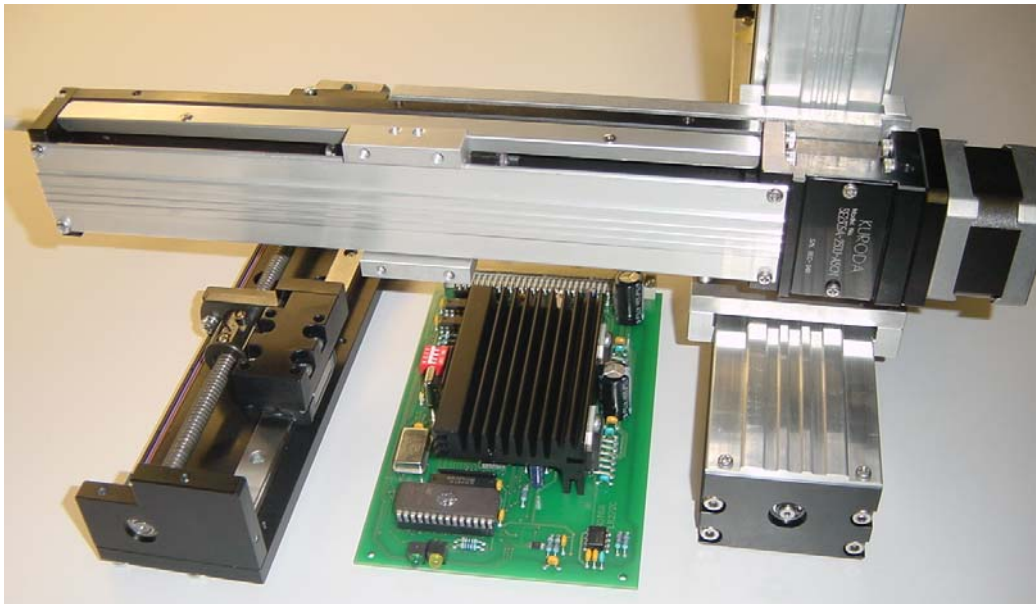

Your Partner for Automation

## ROTRA – since 1987 Your Partner for Automation

**RO** tation + **TRA** nslation = Automation

We are an independent company with many suppliers, customers and partners.

Based on the expectations of our customers we offer components and complex solutions. Many innovative, in part patented systems have been developed and built.

Our customers are big companies as Bosch or Philips, but also many companies not so well known but well doing in the field of new technologies.

We have developed a laboratory robot used to analyse the human's genome. The robot is delivered by our customer to end users worldwide for many years already. Rotra is delivering the mechanical and electrical drives and the controllers.



In close co-operation with the Fraunhofer Gesellschaft we supply machines for the calibration of laboratory glassware. Our customers are many well known glass manufacturers worldwide.

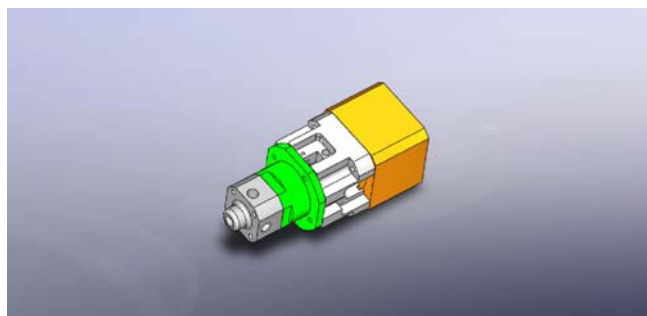

Via ROTRA you can get a direct contact to a network of developers, suppliers and users.

## Idea - Development - Manufacturing - Control - Application

We have gained experience in all steps from the idea to the application.  
Many solutions are elaborated in close co-operation with the customer or end user.

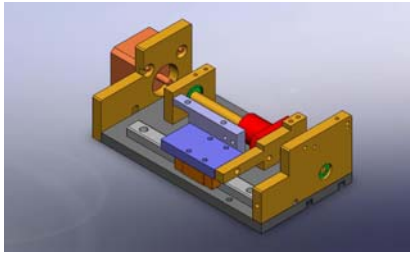

Own CAD development



Own electronics development

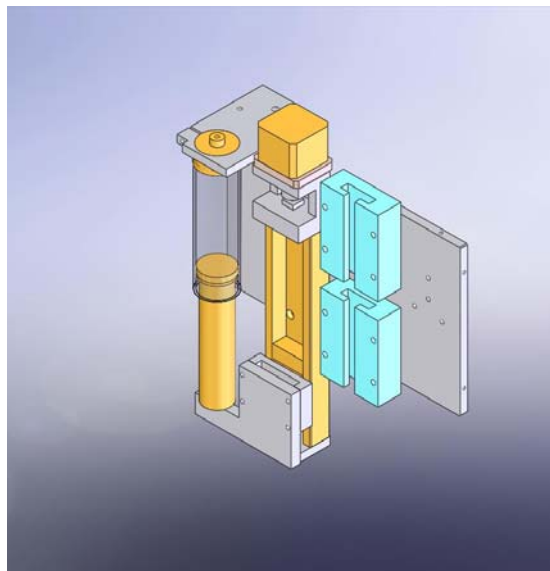

Manufacturing of subsystems and whole machines

# Components

Ball screws and drive modules

## KURODA



We supply products of KURODA Precision Industries Ltd. (Japan)

[www.kuroda-precision.com](http://www.kuroda-precision.com)

High quality ground and rolled ball screws for the automation industries.

New F series - innovative design for low noise at high speed.

Input speed up to 5000 U /min for diameters up to 25 mm

Diameter mm	F Series lead mm
20	10 20
25	5 10 25
32	5 8 12 16
36	12 16
40	8 10 12 16

Recommended - GG and GE ground - GW and GY rolled series.

Diameter mm	ground lead mm	rolled lead mm
8	1 2 4	2 4 5 8
10	2 2.5 4 10	2 2.5 4 5 10
12	2 2.5 4 5 10	4 8 10
15	2 4 5 10 15	5 10 16 20
16	16	32
20	4 5 10 20	5 10 20 40
25	5 10 25	5 10 25
32	5 10	10 32

## Very High Lead

The ground ball screws of the HG series enable high speed.

1 m/sec. at 1000 U /min with small stepping motors possible.

Type	Diameter mm	Lead mm	V m/sec. at 1000 U/min	Force N at 1 Nm	Max. Length mm
HG 0606	6	6	0,1	1047	207
HG 0812	8	12	0,2	524	340
HG 1230	12	30	0,5	209	800
HG 1520	15	20	0,33	314	1500
HG 1525	15	25	0,42	251	1500
HG 1540	15	40	0,66	157	1100
HG 1632	16	32	0,53	196	1500
HG 2020	20	20	0,33	314	1500
HG 2030	20	30	0,5	209	1500
HG 2040	20	40	0,66	157	1800
HG 2060	20	60	1	104	1500
HG 2525	25	25	0,42	251	2000
HG 2550	25	50	0,83	125	2015
HG 3264	32	64	1,1	98	2100

## Actuators with integrated ball screw and linear guide.

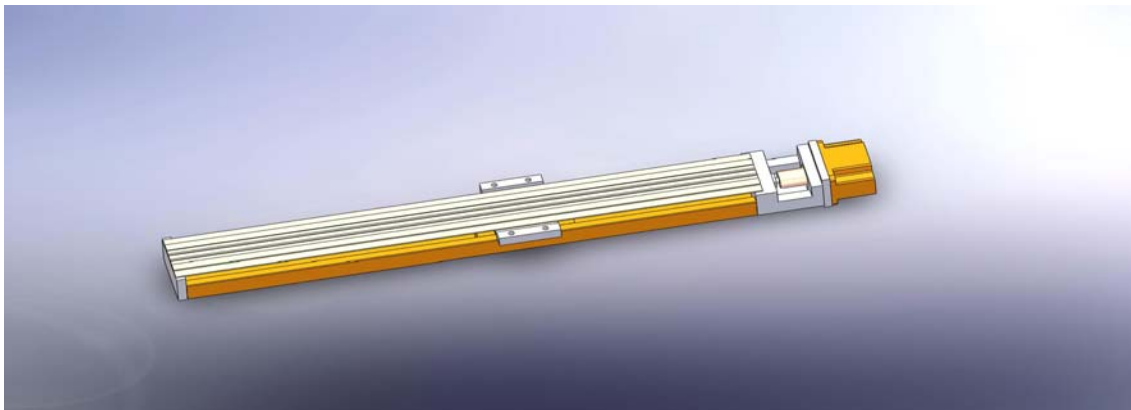

### SE with rolled ball screw

Type	Width mm	Lead mm	Length mm
SE 23	50.5	2 5	150 - 300
SE 30	60.5	4 5 10	150 - 750
SE 45	86.5	5 10 20	540 - 940

### SG with ground ball screw

Type	Width mm	Lead mm	Length mm
SG 20	40	1 5	100 - 200
SG 26	50	2 5	150 - 300
SG 33	60	5 10	150 - 600
SG 46	86	10 20	340 - 940
SG 55	100	20	980 - 1380

## Stepping motors

Stepping motors used with our micro step drivers and controllers enable an easy to control of high resolution drives.

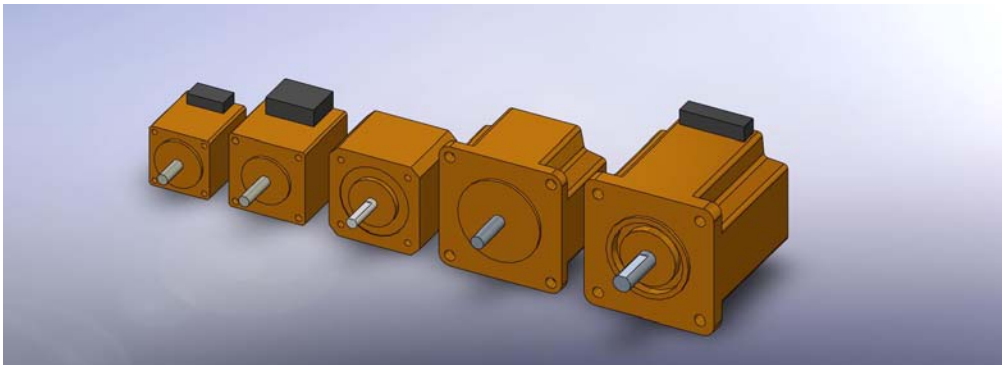

The typical resolution of 200 steps/ rotation is increased 5 to 200 times by the micro stepping. Resulting resolutions of up to 40 000 steps / rotation are possible.

Using high lead ball screws with high lead of 40 mm will still give a resolution of 1 $\mu$ m / step.

A very important advantage of using stepping motors is the no motion behaviour when in position – a must for applications in the micro- and nanotechnologies.

We supply stepping motor systems with servo motor performance.

## Measuring systems

Really high positioning accuracy can be achieved by using glass based linear scales.

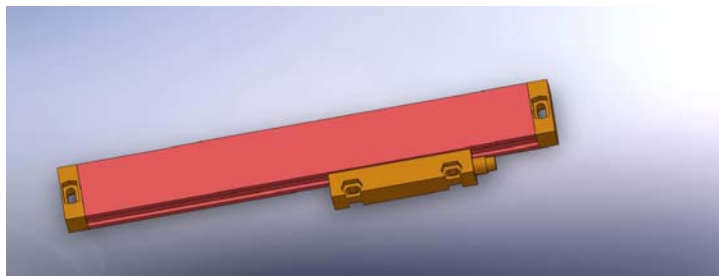

Our axis controllers use the digital signals for positioning and counting. Positioning accuracies of 0.01 mm, 1  $\mu$ m or 0.1  $\mu$ m are possible.

Systems with resolutions of 0.1 $\mu$ m have been supplied for:

Gene technology – work with microscope

Extruder – foil thickness measuring

Heavy Ion Research Institute – positioning of sensors

## **Linear guides**

We co-operate with manufactures of linear guides. Application specific selection is provided.

## **Video and picture control**

We use pictures from integrated video systems for positioning and measuring purposes.

## **Force controlled systems**

Our axis controllers can analyse analogue signals. It is possible to use force sensors in positioning systems. We can define a force for pressing or finding an object or follow the sensor in a way of a power steering.

## **Customer specific axes**

We build and supply customer specific axes using components selected by the end user or recommended by us.

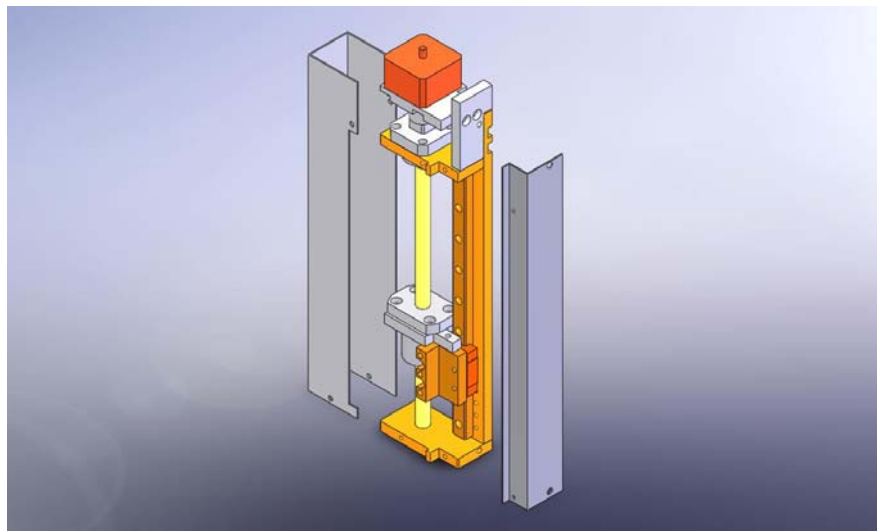

## Controllers ROTRA

Controllers are the core of automation. We have developed individual solutions for different applications.

Every drive axis is equipped with an axis controller with a microprocessor. A master controller or a PC can communicate with many of such axis controllers. There is no limitation for the amount of axes.

Programming, installation and test are easy to understand due to the modular structure and the use of parallel processes. All customer commands are pure text commands.

The communication with the PC is via Rs232 or USB.

Our master processor boards can communicate with 12 axes.

Interpolation using all 12 axes (not in real time) is possible. The PC based program calculates the complicated motions, transfers the position commands as a package to the master. The master controls by hardware the status of the slaves and executes the program flow.



Example: 3 Stations of 5 axes each controlled via 3 independent USB channels.



Example: controller with display, build to customer's wish



## Axis controller ROTRA

Universal axis controller with micro stepping for 2-phase step motors



One board is providing:

LR272C basic version

- Microcontroller
- Serial port TTL
- 8 digital outputs TTL
- 8 digital inputs TTL
- 4 digital inputs for limit and reference switches
- 2 analogue inputs 0..5 V
- 2 D/A converter for variable micro steps 1/4 to 1/200

- Driver with power stages
- 2 phase a 2.5 A at 12 to 50 V
- max. driving current adjustable by software
- max. holding current adjustable by software

- Software in EPROM
- Communication with master or PC
- Selectable axis number (DIL switch)
- Ramp generation for acceleration and deceleration
- 100 speeds, 20 ramps
- Automatic step length adjustment
- Limit switch control, reference drive
- External pulse input possible
- Customer specific subroutines available

- LR272C CL version with encoder counter
- 32 bit counter for encoder signals
- 3 Line Driver 20mA receiver for (A,B,Z) signals
- Positioning in closed loop using encoders or glass scales

Short delivery time.

We have developed a series of application specific controller boards. The in house board layout enables the use of up to date electronic components.

We are using modern CPLD (complex programmable logic device) to integrate the function of many ICs in one device. A compiler software is taking the job of defining the inside routing of the CPLD. The boards are smaller and less complex by using such components.

We integrate analogue input and output devices according to customer's wish.

## Glass industry

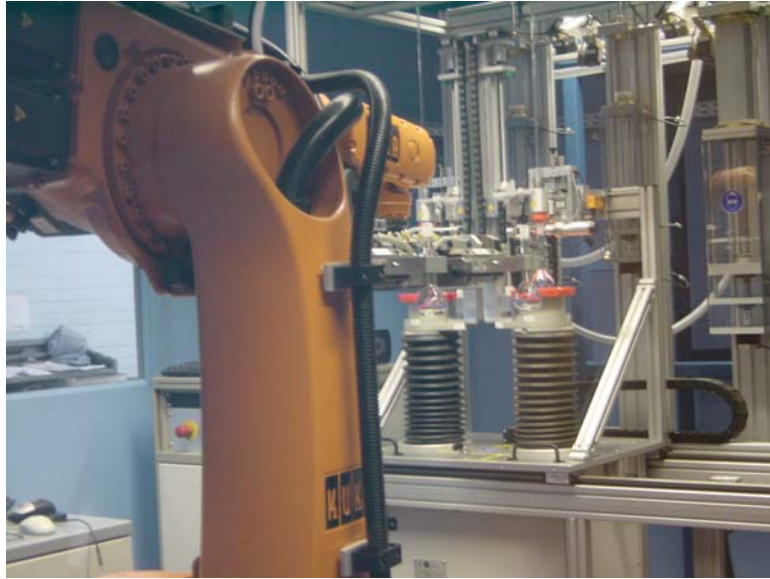

The picture shows a fully automatic – Speed Aquajust – for calibration of flasks.

The flasks are filled with an accurate amount of water, the meniscus is located, a marking provided, rechecked if marking fits to the meniscus and brought back to the production line.

We are co-operating with the German research institute Fraunhofer Gesellschaft. A series of machines for calibration of flasks, cylinders, pipettes, burettes can be delivered.

Machine types as Aquajust, Autojust, SpeedCal, QCC – Quality Control Center can be viewed at [www.isc.fraunhofer.de/bronnbach.html](http://www.isc.fraunhofer.de/bronnbach.html) .

Special ROTRA know how.



Force controlled grinding of glass cylinders with optical control.

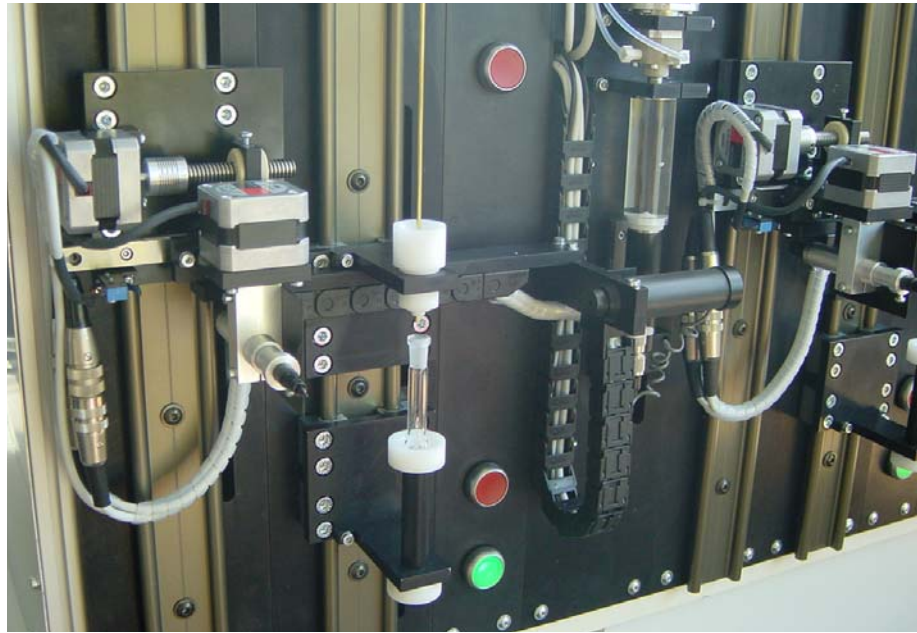

### Machines

Compact 3 station calibration machine for volumes up to 30 ml.

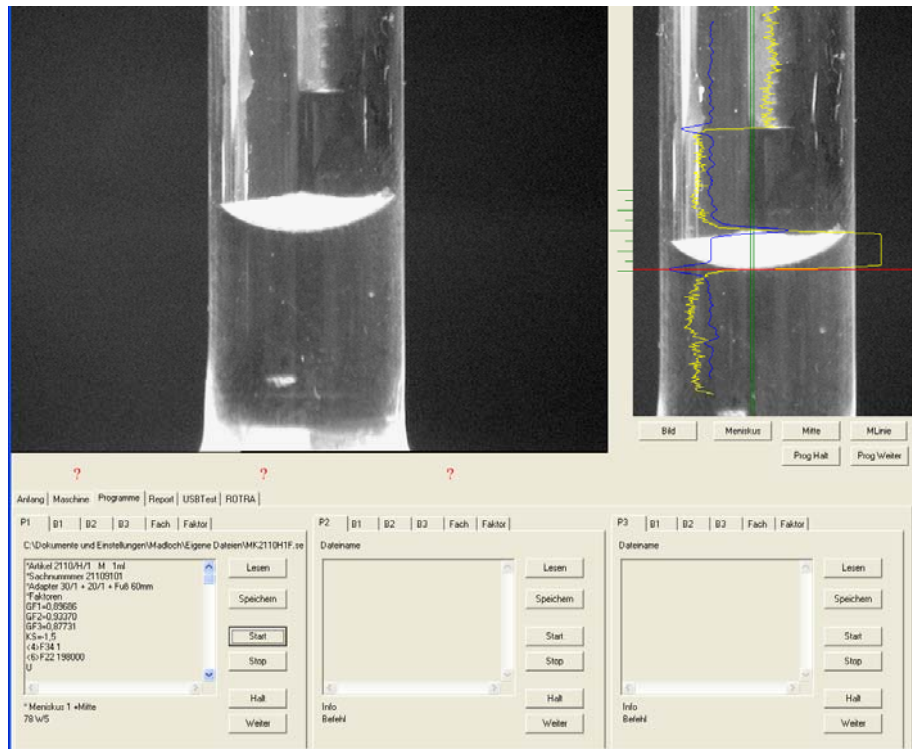

### Software

The use of video processing enables precise positioning and measurement.

We provide solutions for your ideas and jobs.

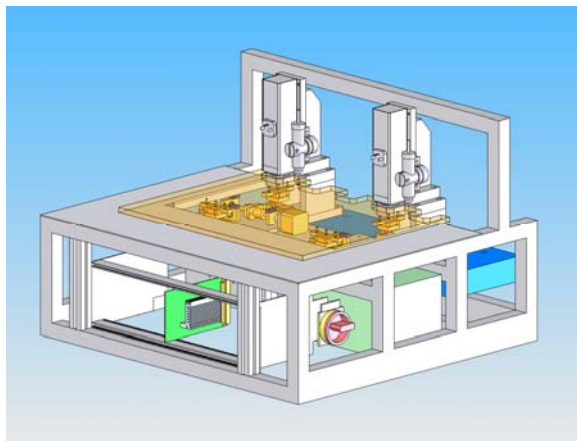
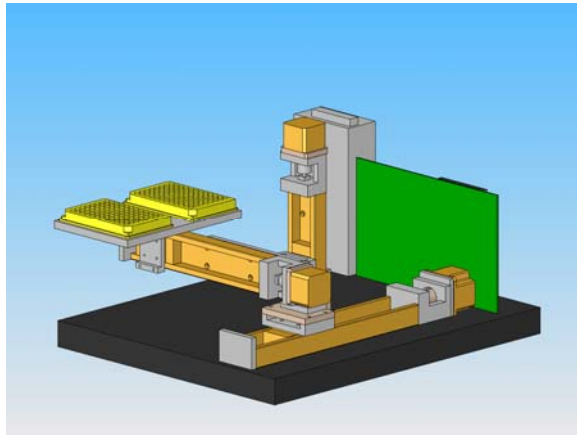

Please ask for more info:

[www.rotra-tech.de](http://www.rotra-tech.de)

[info@rotra-tech.de](mailto:info@rotra-tech.de)

ROTRA Antriebsentwicklung GmbH

Daniel-Müller-Str. 39

D-64347 Griesheim

Germany

Tel: ++49-6155-61306

Fax: ++49-6155-65020

RKE - 2010